

C-C
Typical welding.

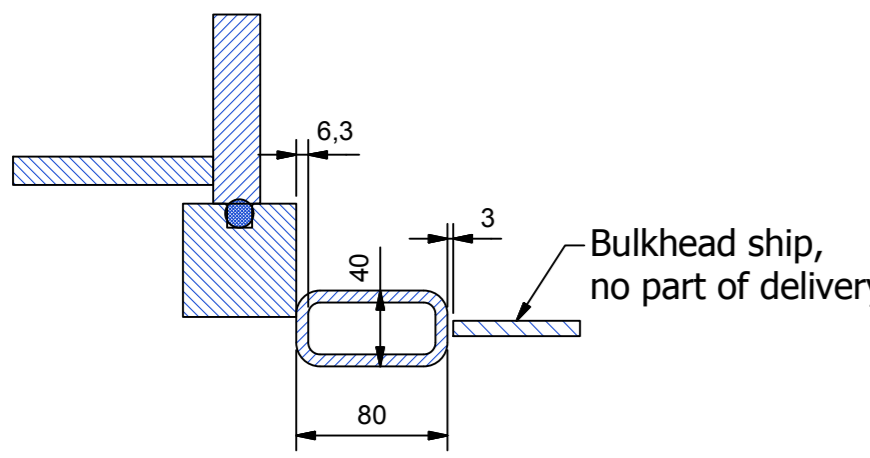

D-D
Typical welding.

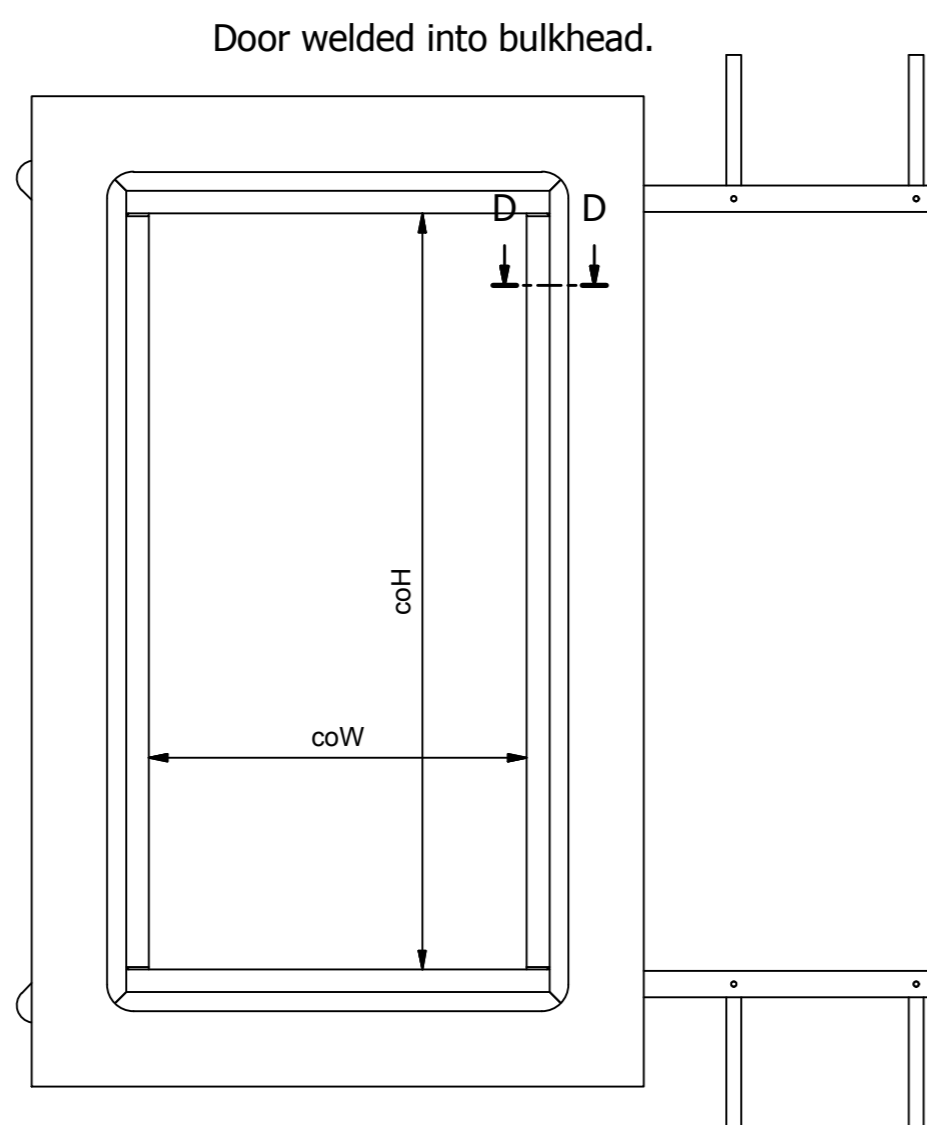
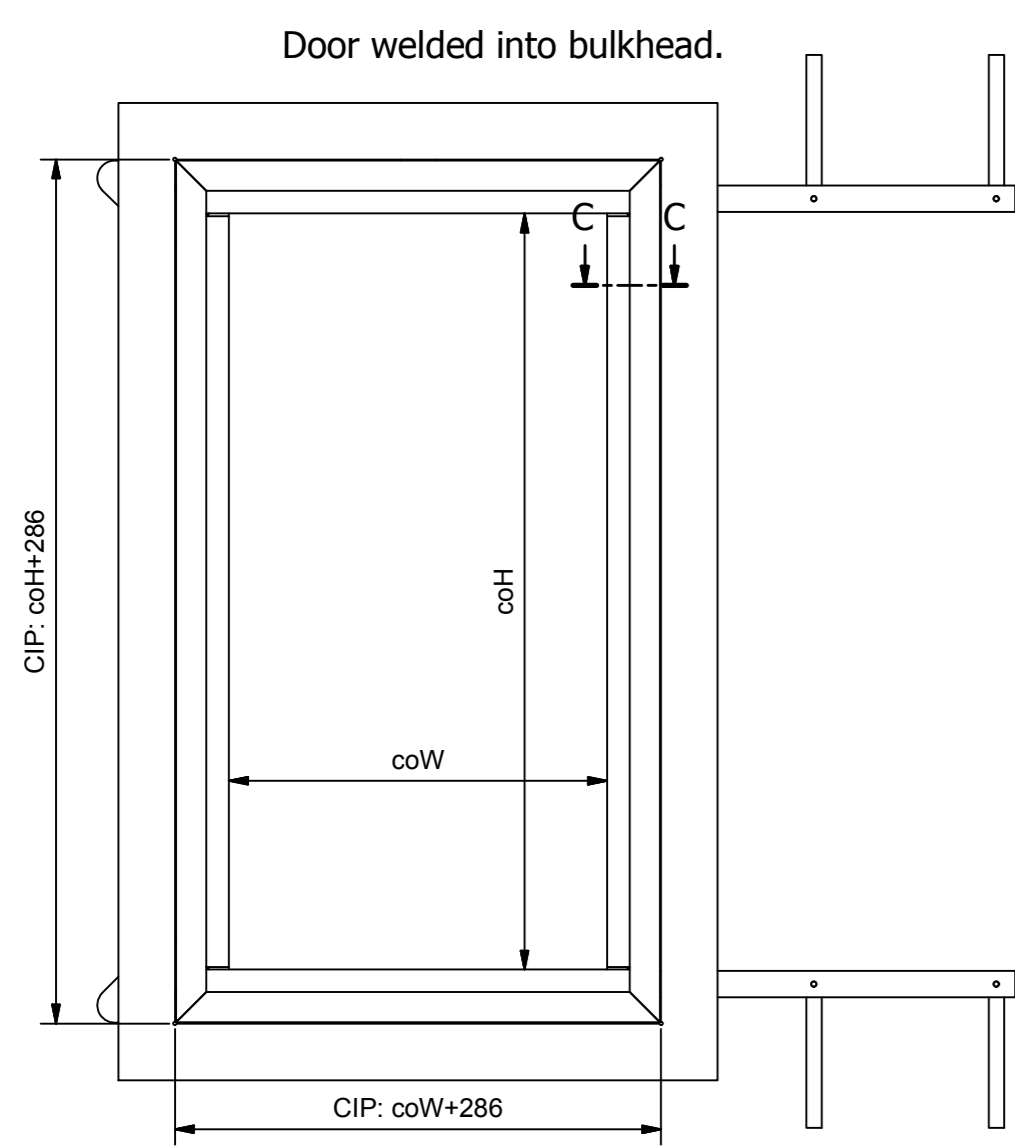
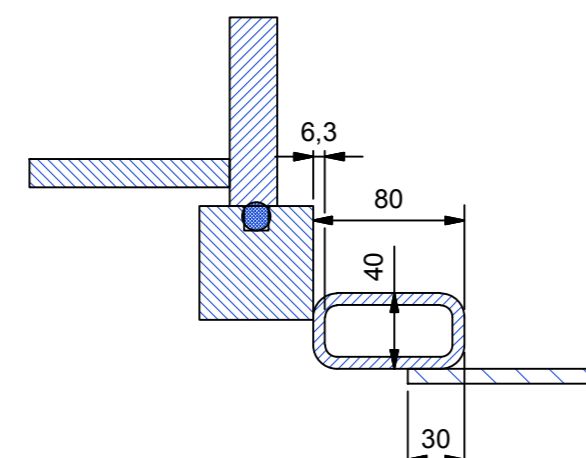

Description:		Name:	Date:	Rev:
Dimensions in mm.		Drawn:	J.G.	6-10-2016
Description:		Engineer: J.G.		
Reference:		Drawing number:		
Reference:		440.52 co HxW		
American projection:		Paper size: A0		
WINEL Assen The Netherlands		The drawing and design shown is our property and may not be used or disclosed for any third person without our specific written approval.		