

Are delivered with overlength,  
to be positioned and cutted on right length by yard.

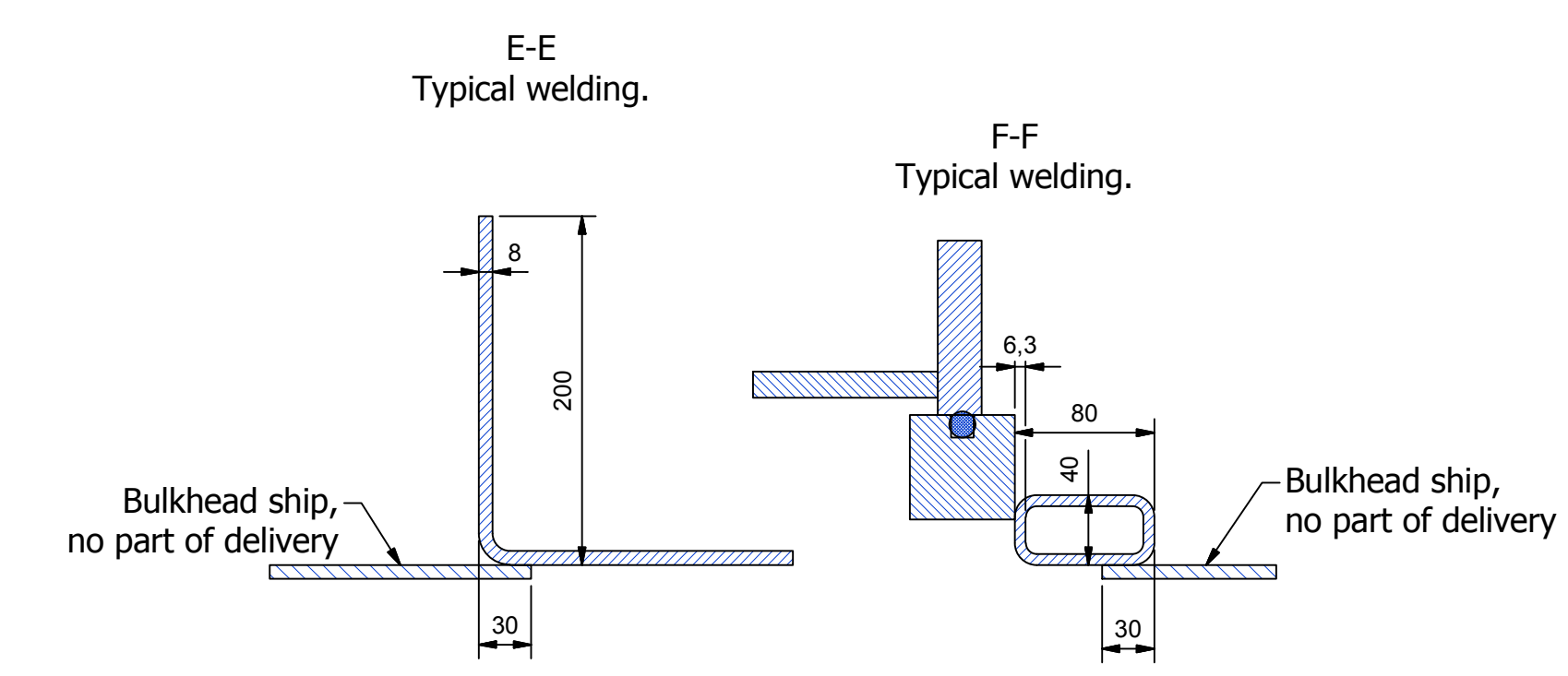

Door welded into bulkhead.

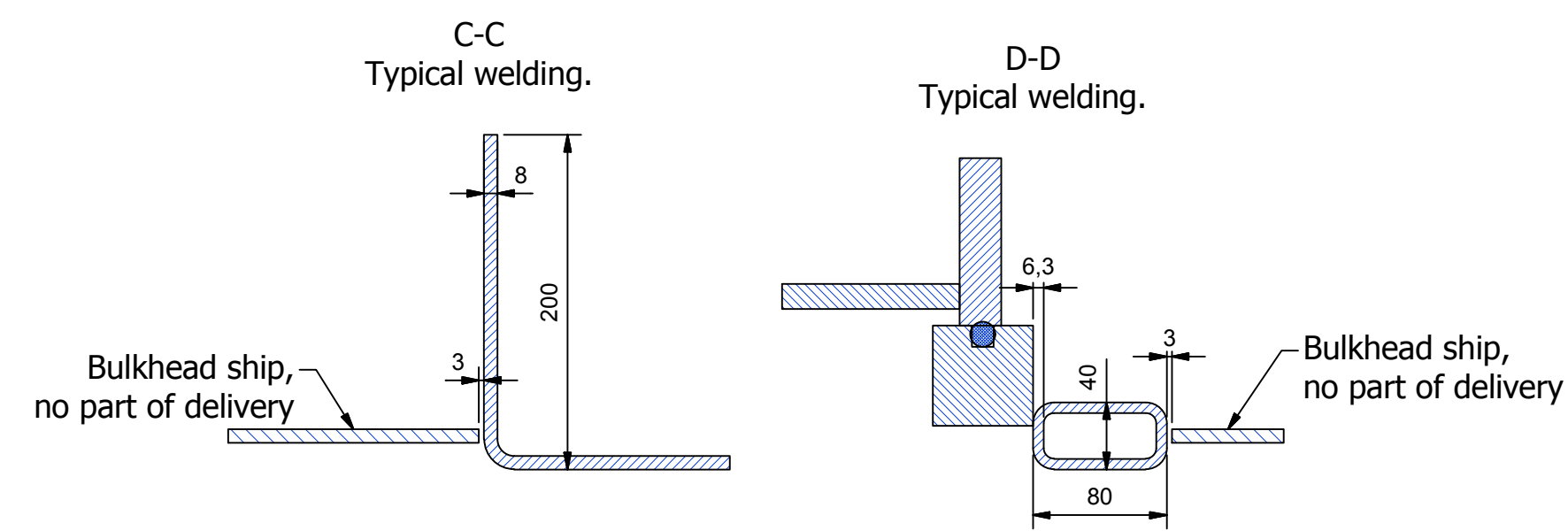
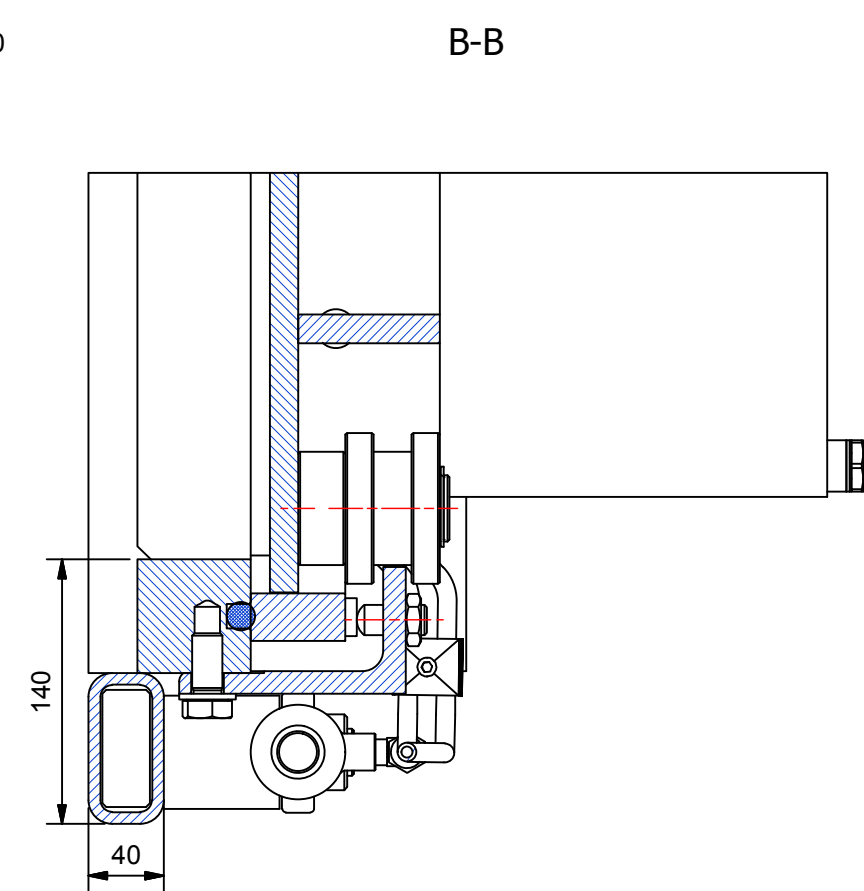
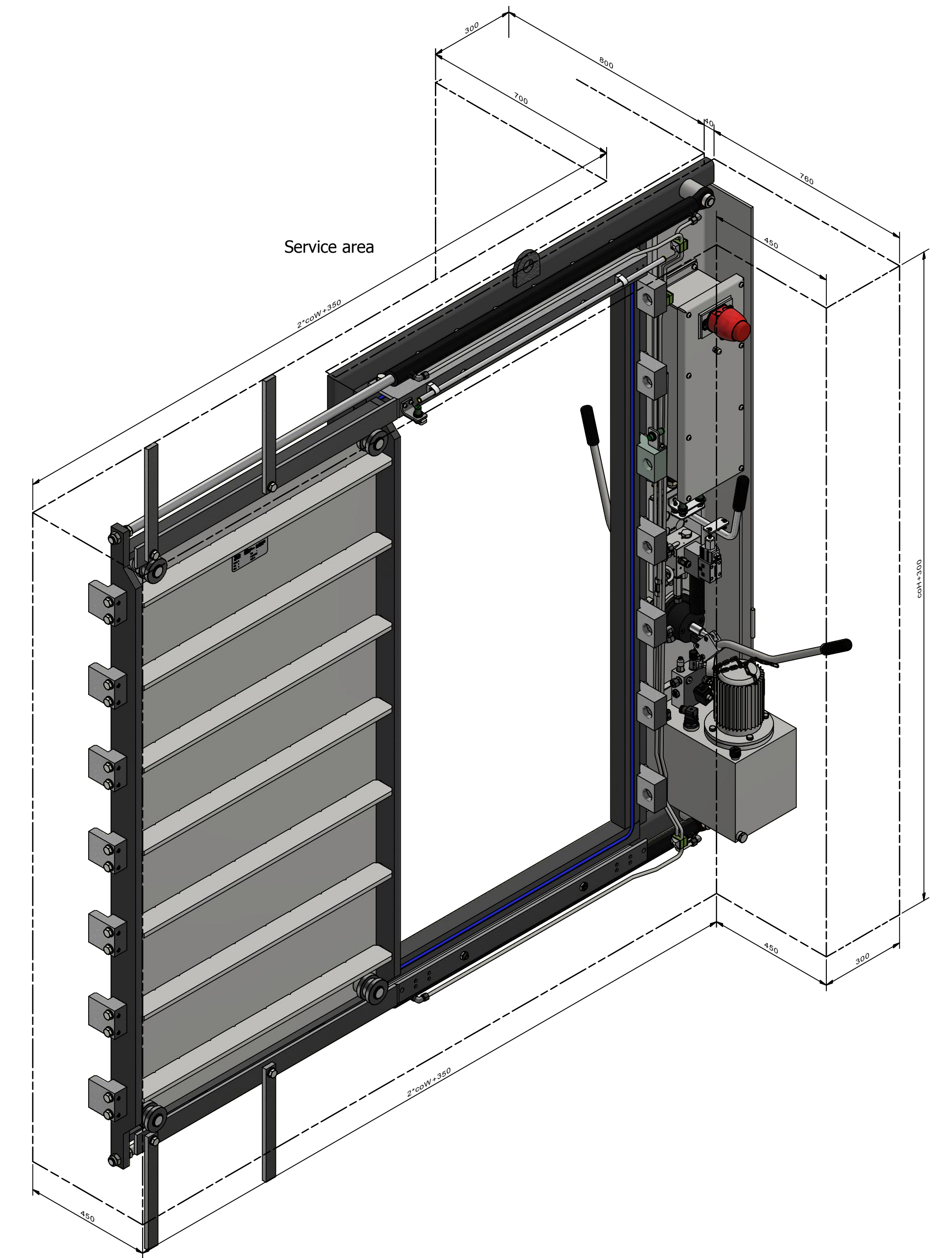
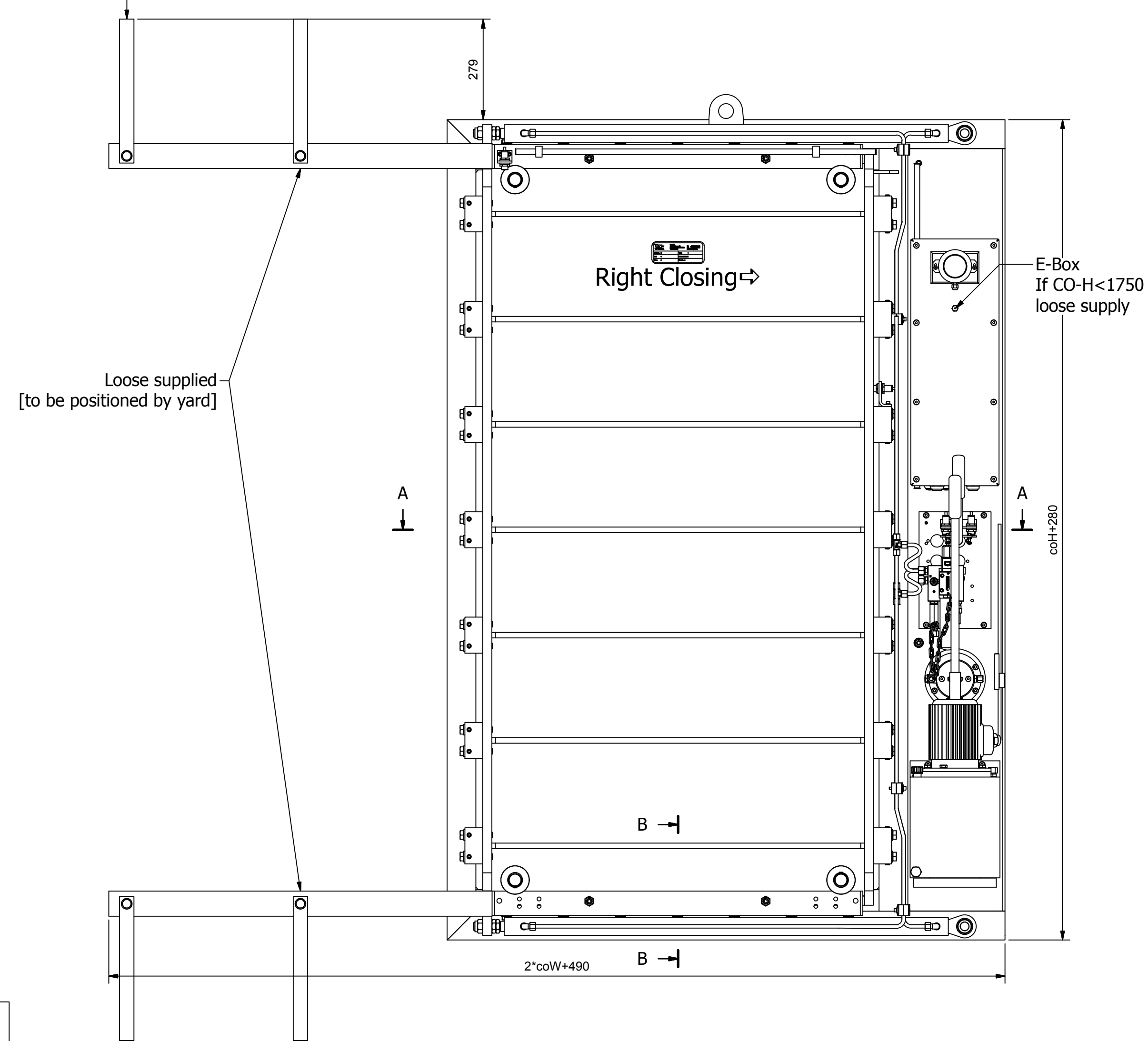
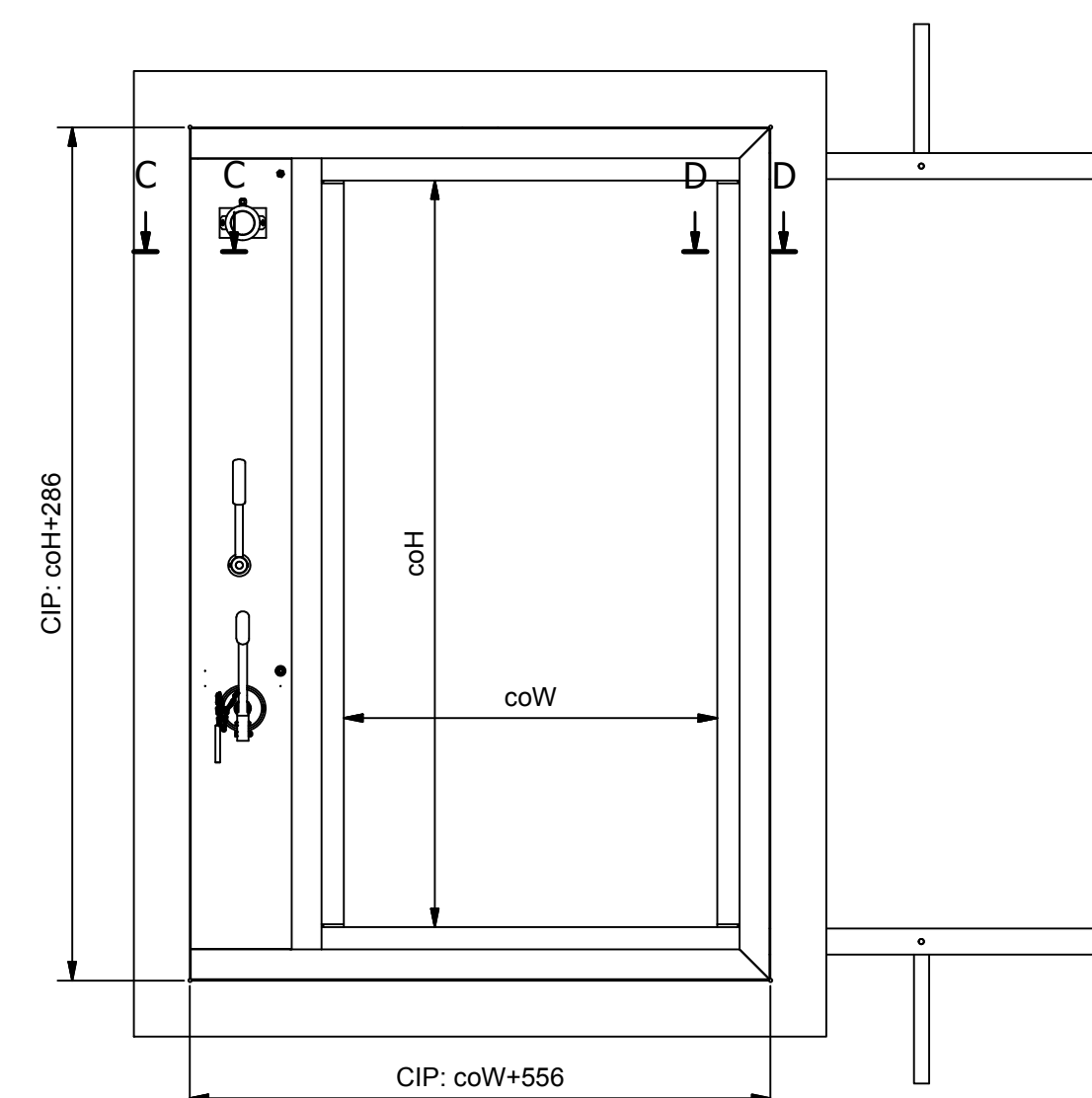

Door welded against bulkhead.

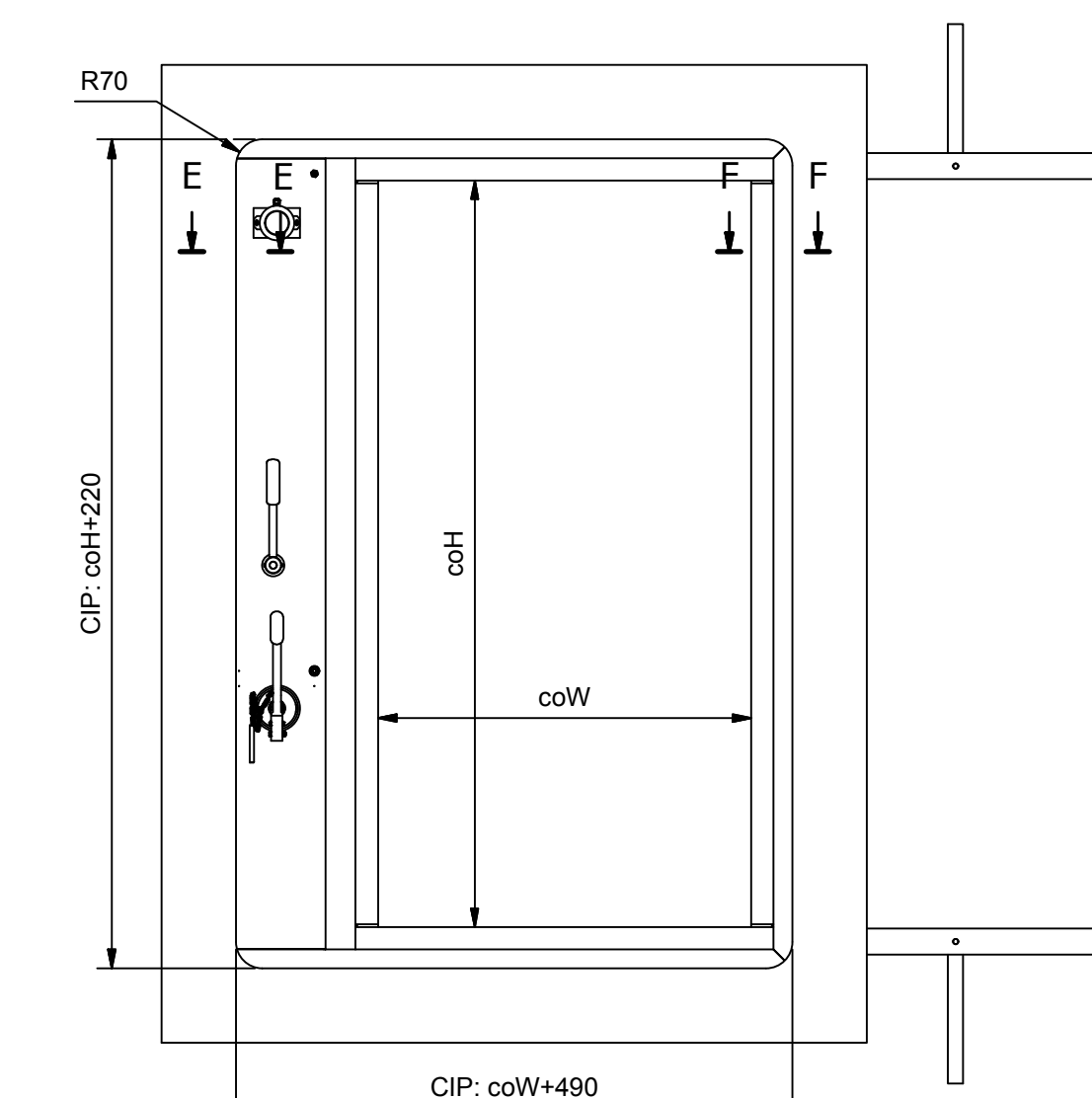

Description:		Name:	Date:	Rev:
Weight:		Drawn:	J.G.	2-6-2016
Dimensions in mm:		Engineer:	J.G.	
Description: <b>Albatros 2 cyl RC</b>				
Reference: Drawing number: <b>443.52 co HxW</b>				
 Assen The Netherlands				