

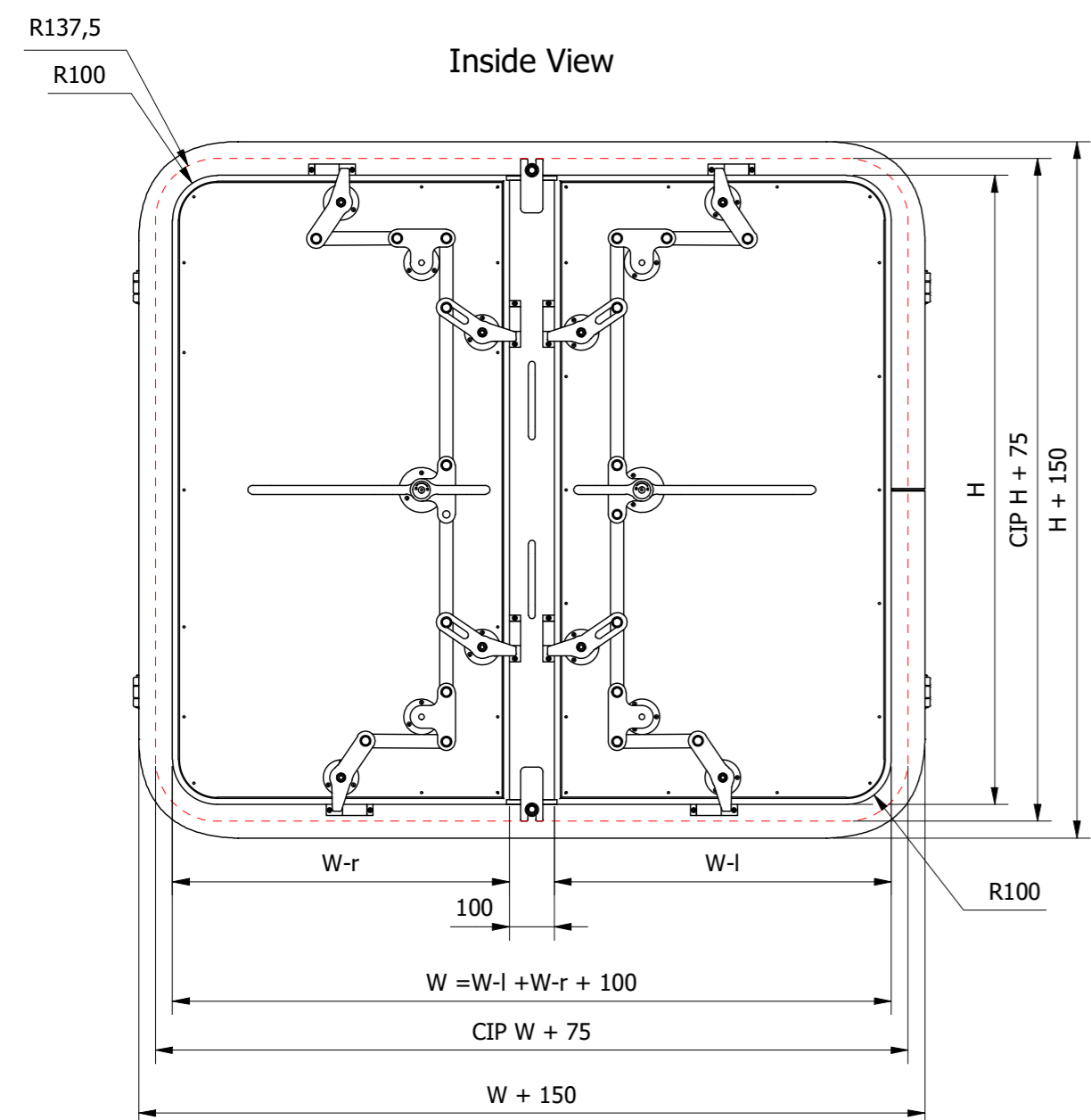

- Doorplate: Grade A / Aluminium / Stainless Steel ; 8 mm
- Coaming: 75x50x7 Steel / Aluminium / Stainless Steel
- Cleats: Cast stainless steel: 1.4408 / ATSM CF8M equivalent to 1.4404 / AISI 316
- Mechanism: Stainless Steel 1.4404 / AISI 316L
- Seal: Seal 42.5x20.4 EPDM
- Wedge: Brass / POM
- Hinge: Stainless Steel or Aluminium with Orkot® bearing and Stainless Steel Axle
  
- Insulation : Rockwool Marineslab 55 or FireMaster Marine Plus Blanket :40mm / 70 kg m<sup>3</sup>
  
- Clear Opening: H x W
- Cut in plate: H + 75 x W + 75
- Outside dimensions: H + 150 x W + 150
- Handle length: L =375

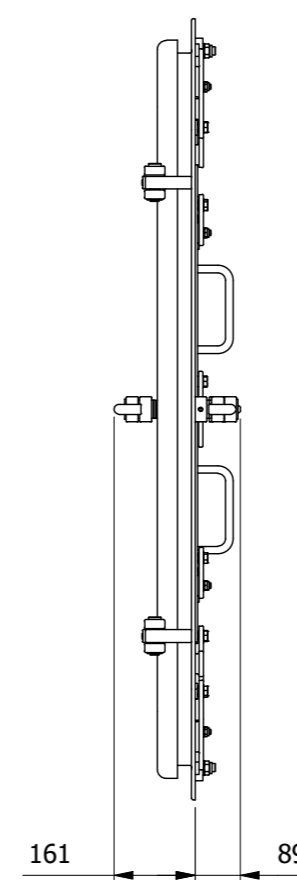

Outside View

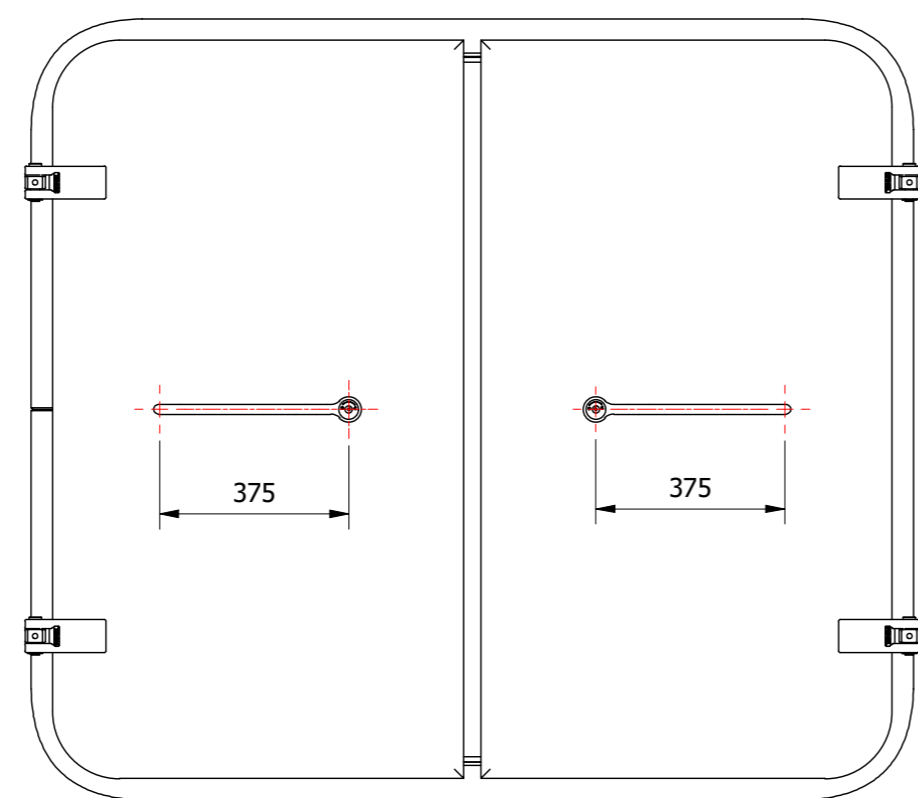

Revision Description		RM	8-6-2023	-
Name	Date	Rev		
		Status:	WorkInProgress	
		Engineer:	RM	17-7-2018
Description:		WET Double Musketeer Door, 4 Cleats , mullion bar		
Reference:		Winel Product Catalog		
Drawing number:		Rev.	Sheet	Size
9542.9 XXXX		-	1 / 1	A2
 info@winel.nl Dr. A.F. Philipsweg 55 www.winel.nl 9403 AD Assen +31 (0)592 366 060 The Netherlands				
The drawing and design shown is our property and may not be used or disclosed for any third person without our specific written approval.				