

**Deck Hatch flush coaming
Lift out / Toggle operated**

General

The hatches are compact engineered weathertight hatches. It is supplied as a completely finished and tested unit, ready for welding into deck. It combines the well-known proven mechanical design of the hatch. Available in a range of sizes and options.

The design and manufacture of is in compliance with the class and IMO/SOLAS safety regulations for to fulfil the weathertight integrity of the vessel

Description/ operation & control

The hatch is to be opened by using the ship's crane. The hatch is equipped with lifting pockets. Locking by manual toggles acc DIN 83104 from bottom side of hatch.

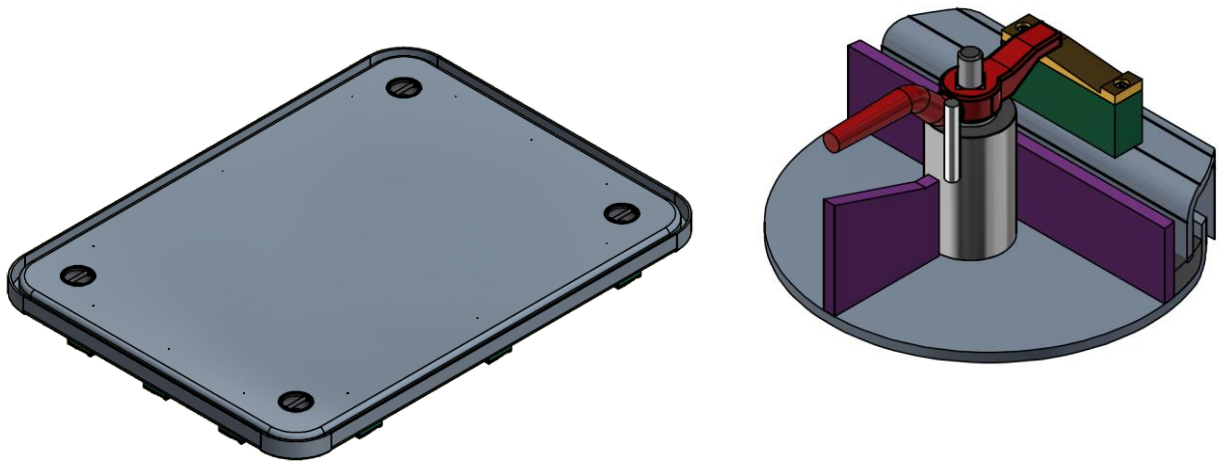

Drains

The hatch is supplied with 2 drain connection in the corners of the coaming

Support in deck

The coaming needs to be supported in deck

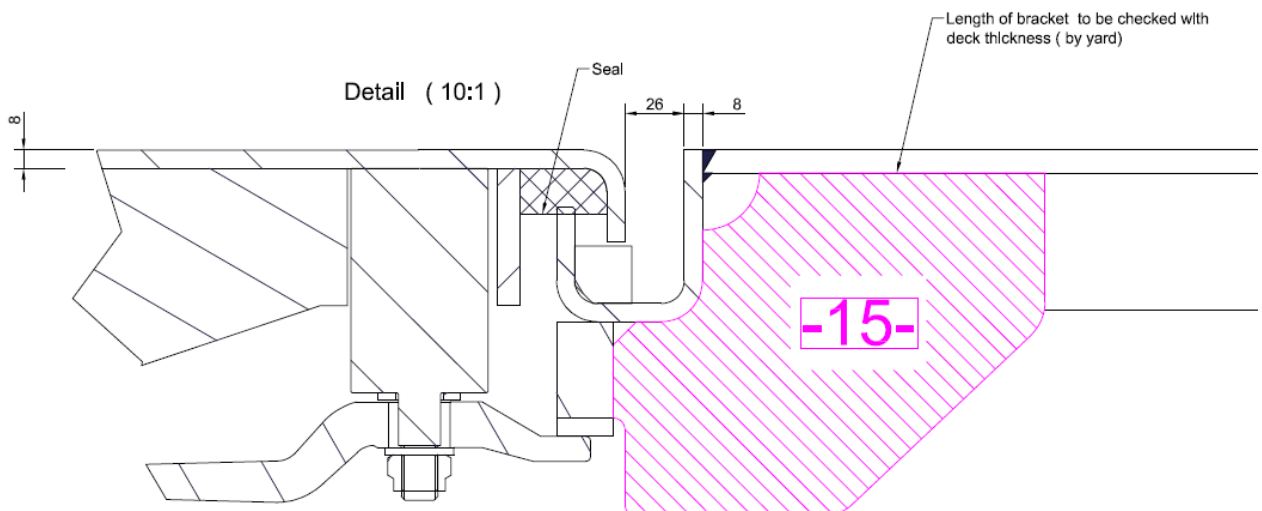

**Deck Hatch flush coaming
Lift out / Toggle operated**

/// Specifications

Size:

3000 mm x 4000 mm; flush; deck load 2 ton / m²

Material

Coaming and cover: Steel Grade A
All Axles and bushes: Stainless steel 316

Water pressure

Weathertight

Surface treatment

See paint specification.

Installation, operation and maintenance manual

Two (2) hard copy in English language.
One (1) CD-Rom in English language.

General arrangement drawings

See GA drawings.

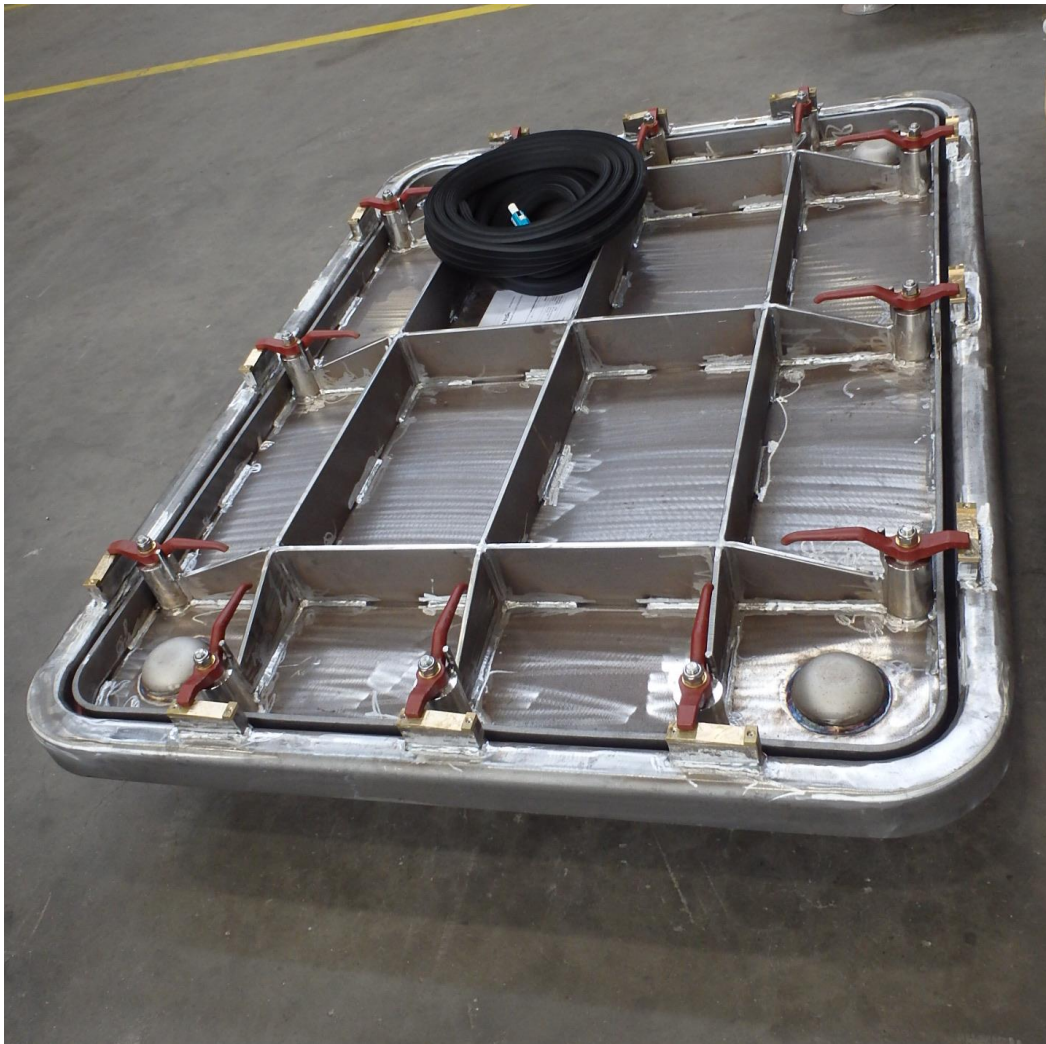

Options

A60 insulation

The hatch blade is insulated with MED approved A60 insulation material for steel deck; single side; A60. Please note that the hatch is not an A60 MED certified hatch.

